



---

**ELEVATOR CABINS**  
EQUIPMENT VARIANTS

**ETG** ELEVATOR  
TRADING  
German manufacturer

SIZES  
WALLS  
CEILING  
FLOOR  
MIRRORS  
HANDRAILS  
ACCESSORY

## Elevator cabin

– variable cabin dimensions according to customer specifications



raw cabin



sheet metal cabin with open through



cargo cabin



glass cabin

## Glass wall panel – coloured glass lining

VSG-panel in aluminium swivelling profiles with metal sheet frames

coloured glass lining

> green glass

> white glass



with a monitor behind the mirror

## Cabin walls

- edged C-profiles
- anti-drone pads on reverse side
- other materials on request
- screwed wall panels
- corner connection elements

### steel galvanized, covered with

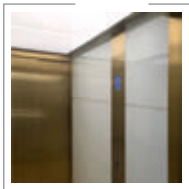

coloured glass (ESG) panel with vertical shadow gap similar to RAL-colours



mirror panel (VSG) with vertical shadow gap

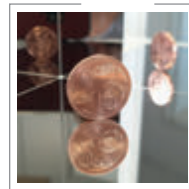

stainless steel super mirror finish (1.4301, AISI 304)

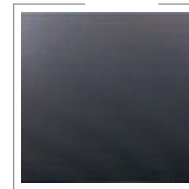

stainless steel „Haze“



HPL panels wood design „Indian Apple“ (dark)



example colour glass panel with digital printing



example granite lining



example coloured glass panel with behind-the-wall monitor



example mirror glass panel with behind-the-wall monitor

### stainless steel ground finished, material quality 1.4016 (AISI 430) / 1.4301 (AISI 304)



grain 240



(fine) brushed



hairline titan ground finished



bronze ground finished



black satin

### stainless steel structured, material quality 1.4016 (AISI 430) / 1.4301 (AISI 304)

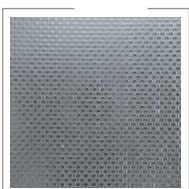

linen

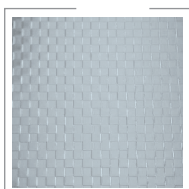

square 21

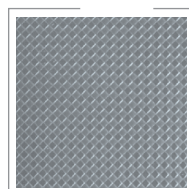

rhomb

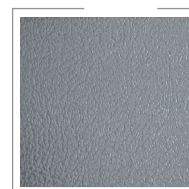

leather



bark

### steel galvanized, plastic coated, powder coated, smooth, fine or coarse structure, colour selection: RAL-Classic (standard smoth, silk gloss according to QIB directive cat. 2 (\*\*)) – gloss grade 50 -80%)



white fine structure (similar RAL 9016)

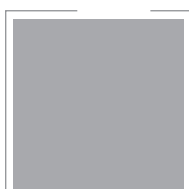

white aluminium smooth (RAL 9006)



sheet metal plastic coated wood imitation – bright (DL68)



sheet metal plastic coated wood imitation – dark (DL51E)



RAL-Classic (other colour systems possible on request)

## Roof and suspended ceilings

- total height 70 mm
- shadow gap 35 mm circular
- roof plain and fully accessible
- suspended ceiling also available as retrofit ceiling

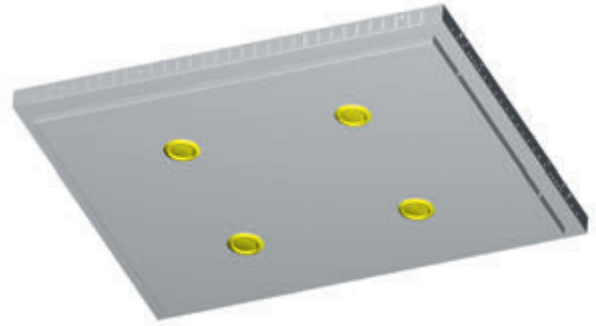

### suspended ceiling, rigid

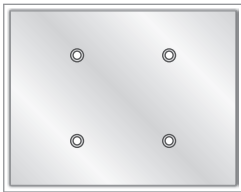

stainless steel ground finished or white fine structure similar RAL 9016 with LED-spots



**LED-spot**  
(3W, 230V AC)



**LED-spot**  
theft-proof  
(3W, 230V AC)

### suspended ceiling, foldable

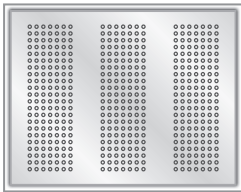

hole pattern (round), regular with LED-light tubes

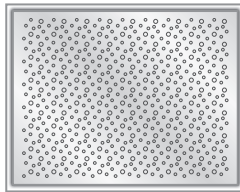

hole pattern (round), irregular with LED-light tubes

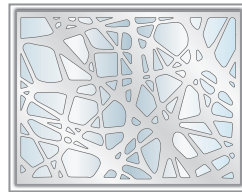

"organic" cutout (irregular) with LED-light panel

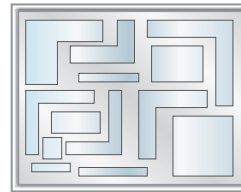

"angles" cutout (irregular) with LED-light panel



light area 550 x 550 mm with LED-light panel

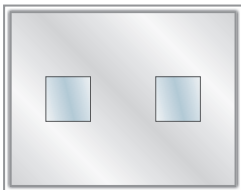

light area 2x 250 x 250 mm with LED-light panel

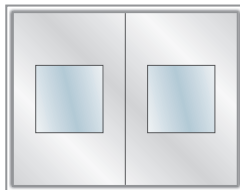

suspended ceiling 2-sectional, light area 2x 550 x 550 mm with LED-light panel

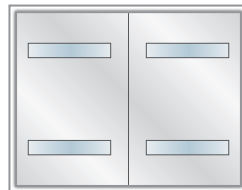

suspended ceiling 2-sectional, light area 4x 150 x 850 mm with LED-light panel

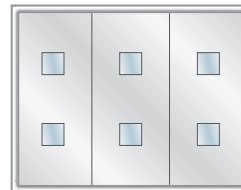

suspended ceiling 3-sectional, light area 6x 250 x 250 mm with LED-light panel



suspended ceiling with full surface LED-light panel, stainless steel frame 60mm circular



example glass ceiling (satin-finish / frosted) with LED-light panel

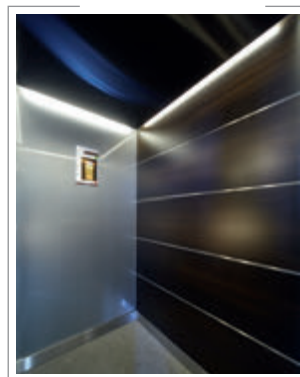

example indirect lighting

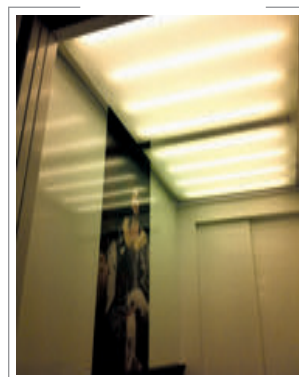

example glass ceiling (satin-finish / frosted) with LED-light tubes

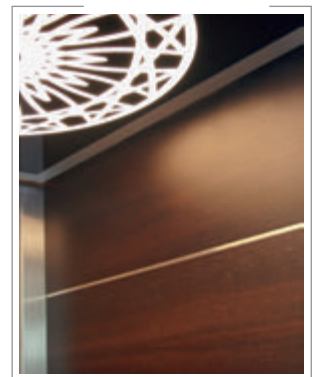

example glass ceiling with ornamental design

## Cabin floor

- sheet metal construction, 70 mm high
- different cover

### Elastic safety plastic carpet, multicoloured, anti-slip property R10

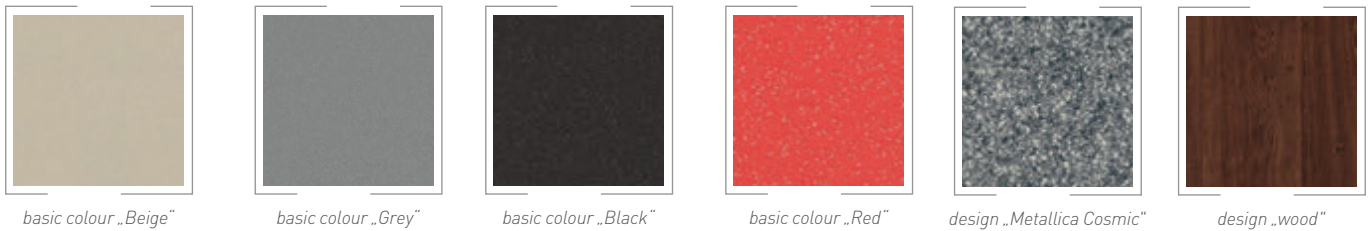

### Bilb plate

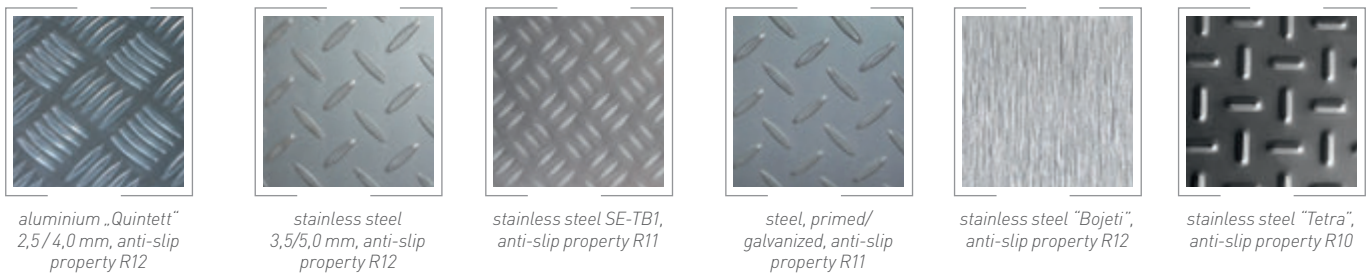

### Agglomerate panels - lightweight panel in natural stone on plastic carrier, 6.6mm thickness

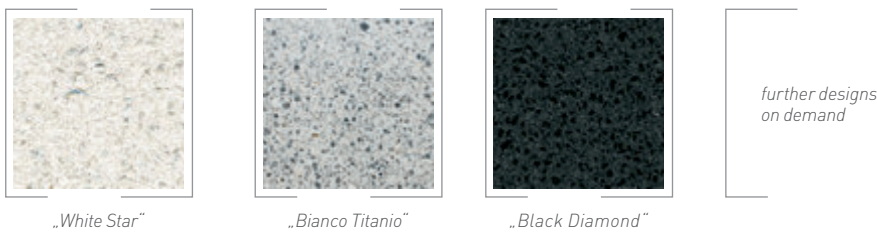

### Granit "Grama Blend" - lightweight panel in natural stone on aluminium carrier, 8mm thickness

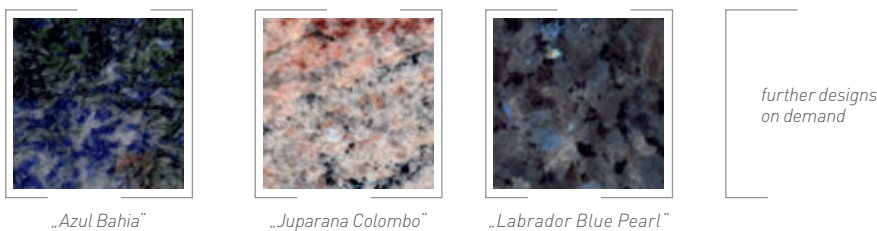

### Rubber carpet, unicoloured with classic round nubs, anti-slip property R9

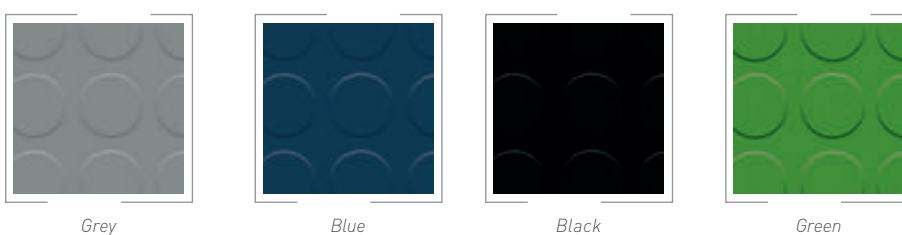

## Cabin mirror



mirror VSG 6 mm crystal, glued on wall, 1/2 height



mirror VSG 6 mm crystal, glued on wall, with a handrail



mirror VSG 6 mm crystal, glued on wall, total height



mirror VSG 6 mm crystal, total height, with a monitor behind the mirror

## Cabin handrail

### Polished stainless steel

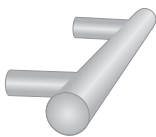

straight Ø33,7 or Ø40 mm



straight Ø33,7 or Ø40 mm



surrounding the corners, rounded, Ø35 or Ø40 mm

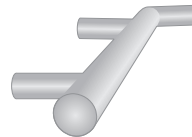

surrounding the corners, bevelled Ø35 or Ø40 mm

### Wood („Beech“ or other kinds of wood)

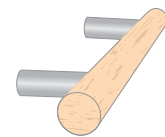

straight Ø40 mm (stainless steel spacer)

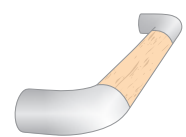

rounded ends Ø40 mm (wood-stainless steel combination)

### Handrail for tube tableau and rectangle-handrail



tube tableau, for Ø40 mm handrail (stainless steel)



rectangular profile 60 x 20 mm (stainless steel)

more models possible

## Cabin fender

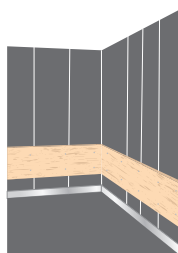

### Fender Wood

- hardwood
- 200 / 100 x 20 mm
- polished und painted
- visible screwing

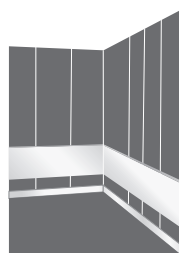

### Fender Stainless steel

- stainless steel grain 240 covered
- 200 x 20 mm, 100 x 15 mm
- stainless steel 1.4016
- hidden fixation

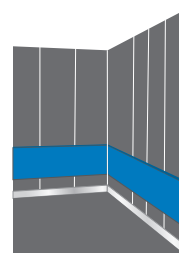

### Fender plastic HDPE

- 200 x 20 mm or on request,
- hidden fixation

- impact protection in black rubber on demand available
- skirt guard as bended C-profil (hidden fixation) 100 x 15 mm or 60 x 15 mm, stainless steel satin

We're always trying to realise other details, sizes, designs or materials. Please contact us for more information.

## Cabin accessory

### Support frame connection

– on consultation

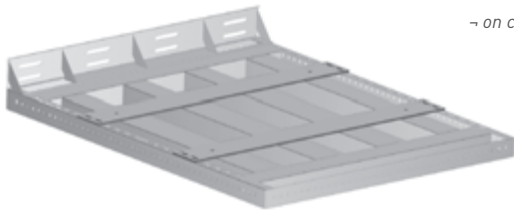

### Door fixation below

– for ETG-doors „Marathon“  
– for doors from another supplier



### Design acc. to fire service elevators (on request)

– opening in roof  
– ladder box with/without door  
– fixation for outside ladder  
– special roof construction

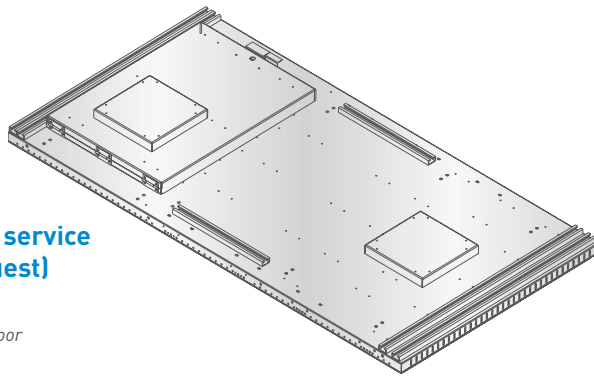

### Preparation for customer panels



### Folding seat without back

– stainless steel  
– attached on the wall  
– stiffened at backside  
– also counter-sunk possible  
– optional plastic coating  
– optional imitation leather pad

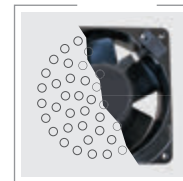

### Fan/ ventilator

– low noise

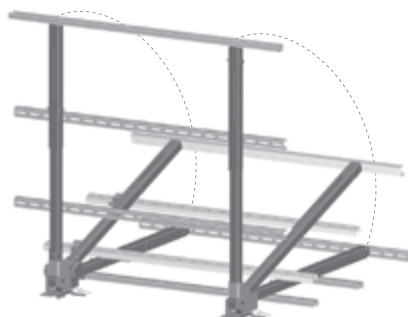

### Roof balustrade

– high 700 / 1100 mm  
– fix, foldable- and/ or teleskop



### Packaging A-frame



---

---

# ETG ELEVATOR TRADING

---

---

German manufacturer

Kömmlitzer Straße 5  
D-04519 Rackwitz

Phone: +49-34 294-1797-00

Fax: +49-34 294-1797-33



[info@elevator-trading.de](mailto:info@elevator-trading.de)  
[www.elevator-trading.de](http://www.elevator-trading.de)

---